

MDP 5011 pump maintenance frequency

Example : for use at 20 °C housing temperature, in continuous operation, at ultimate pressure :

- **16000 h** : 1st lubrication
- **32000 h** : 2nd lubrication
- **48000 h** : disassemble the MDP, replace the ball bearings.

Relubrication schedule (hours)

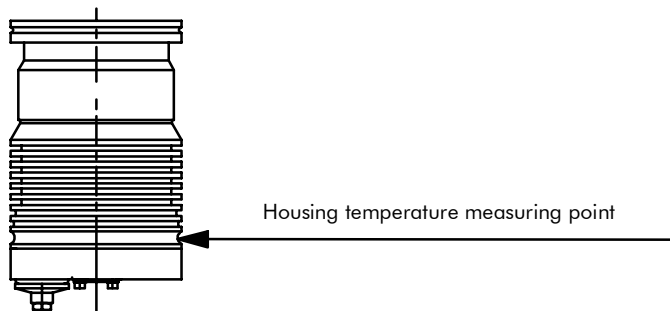
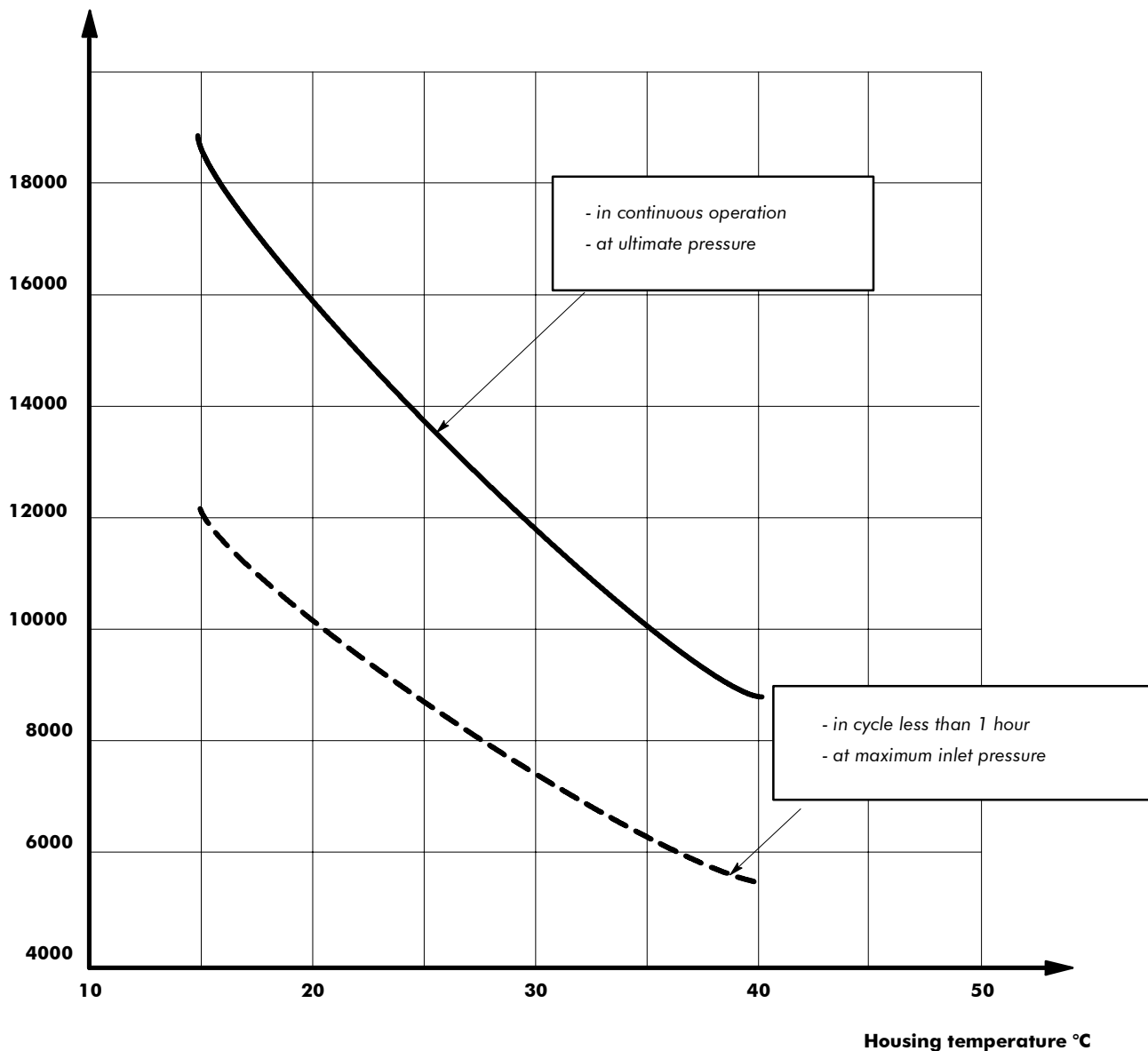

Precautions before maintenance



WARNING

It is important to isolate the machine from the electrical power supply source before any intervention inside the equipment (for maintenance reasons).

Before any maintenance operation, Check the pumping conditions of the installation: toxicity, possible corrosion of the pumped gases. Depending on the case, we recommend:

- to purge the pumping installation with dry nitrogen before any intervention**
- to wear gloves, goggles and breathing masks, if necessary**
- to ventilate the room well and disassemble the equipment under a fume hood.**

After a complete maintenance operation, it is recommended to perform a helium airtightness test.

Similarly, follow all the safety instructions concerning start-up.

MDP 5011 pump lubrication

The first lubrication required for the correct operation of MDP pumps is performed in the factory. Subsequent lubrications should be performed according to the procedure below and according to a frequency defined as a function of processes used (see section D10).

Only use the grease recommended by the manufacturer and contained in the lubrication syringe (see section F10).



WARNING

Avoid introducing foreign matter into the pump during these operations. Lubrication must be performed with the pump switched off.

Use of the lubrication syringe

The ATH contains two bearings which must both be reloaded with grease at each relubrication period.

The syringe is equipped with two jumpers with different widths and colours (red and black) **used to proportion the grease accurately for each pump bearing** (see figure page 2/3).

- Lubrication of bearing on the pumping cell side: **black jumper**.
- Lubrication of bearing opposite the pumping cell side: **red jumper**.

MDP 5011 pump lubrication

RELUBRICATION PROCESS

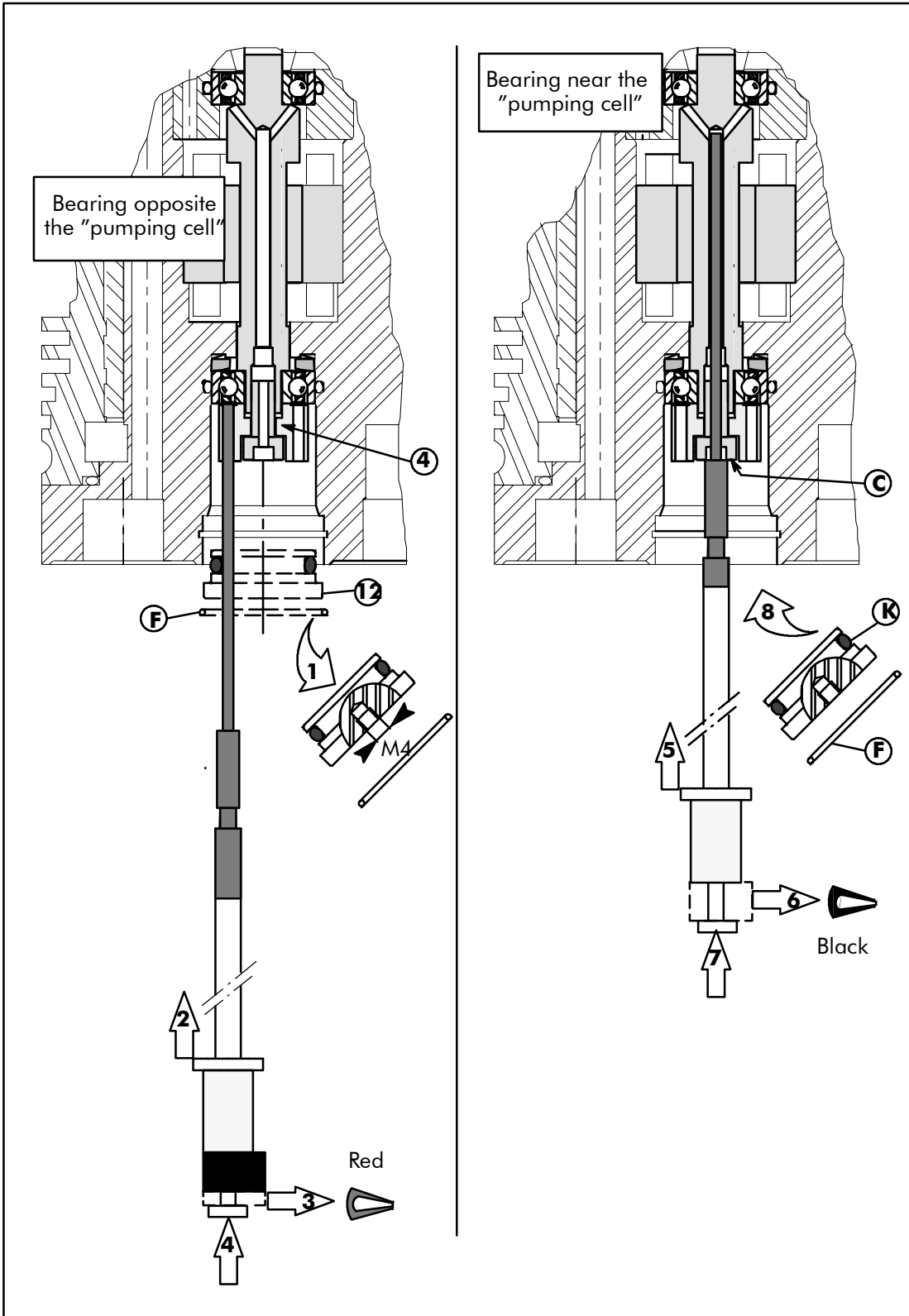

MDP 5011 pump lubrication

BEARING LUBRICATION

- Stop the MDP pump and the primary pump.
- Vent the MDP pump to atmospheric pressure.
- Remove the lock pin (F).
- Tighten a screw M4 in the thread of the end cap (12) and remove it.

Bearing opposite the pumping cell

- Introduce the syringe equipped with its needle into a hole of the ring (4) and remove the red jumper.
- Distribute the dose of grease in 2 diametrically opposed points, until the syringe plunger comes to a stop against the black jumper.

Bearing on pumping cell side

- Introduce the lubrication syringe needle into the drilled screw located at the center of the rotor until it comes to a stop against the screw head.
- Keep the syringe pressed down to the bottom of its housing throughout the operation.
- Remove the black jumper from the syringe and introduce the grease until the plunger comes to a stop.
- Remove the syringe.
- Reassemble the end cap (12) and the lock pin (F) .

The relubrication operation is complete.

Execute the pump running-in (See section E 30).